

Quick-Step® Hydrokit



Product:

Quick-Step Hydrokit is a high-quality professional, transparent and elastic one-component joint sealant based on silicones. Waterproof and in transparent color.

- Ideal for watertight sealing of connection joints between skirting boards and walls, along walls, stairs, radiator tubes, etc.
- Perfect for watertight sealing of profiles.
- Perfect solution for Quick-Step laminate (waterproof) and LIVYN (perfect adhesion on vinyl floors).
- In general: excellent adhesion on Quick-Step laminate, LIVYN and parquet, aluminum (profiles), MDF, melamine, PVC.
- UV-resistant: maintains adhesion and consistency in UV-light.



- Contents: 310 ml
- Code: QSKITTRANSP
- Packaging quantity: 12



Characteristics:

permanent elasticity, easy to apply, water resistant, neutral, low odor and non-corrosive.

Frost free: resistant to temperatures between -60° and +180°C.

Usage:

12 m/tube (joint 0.5 x 0.5 cm).

Instructions:

- Apply Quick-Step Hydrokit using a caulk gun on a clean, dry, dust-free and grease-free surface; then smoothen with a putty knife.
- The Quick-Step Hydrokit should preferably be applied at temperatures between +5°C and +30°C.
- Maximum expansion of 25%.

Storage life

Shelf life min. 15 months after production date (refer to batch code) if stored unopened in a cool dry place.

💡 For more info: www.quick-step.com.

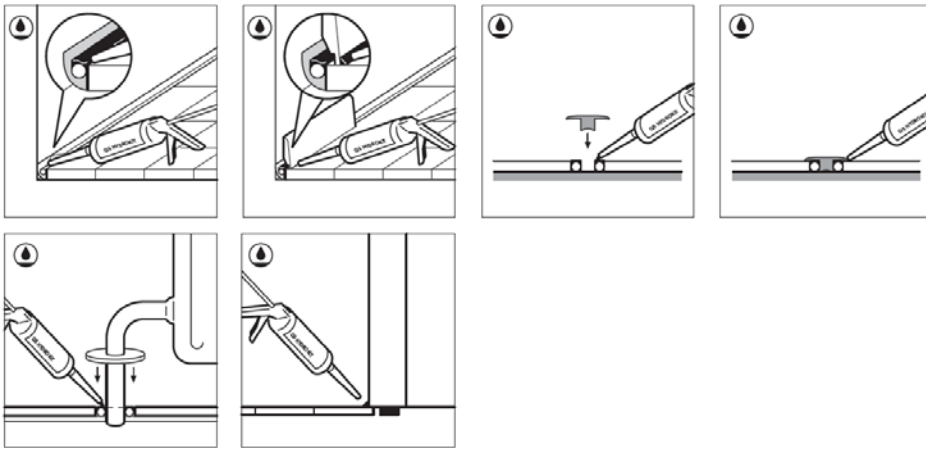

Applications

The use of Hydrokit is in the below drawings marked in **blue**.

Remark:

This is how a perfect watertight installation of your skirtings can be achieved: use our PE foam strip (NEFOAMSTRIP20):

- Underlay to be installed with flap folded upwards
- Extruded profile (foam) to close the expansion gap and avoid excessive use of the hydrokit
- Our skirtings are finished with a water repellent coating at the bottom.

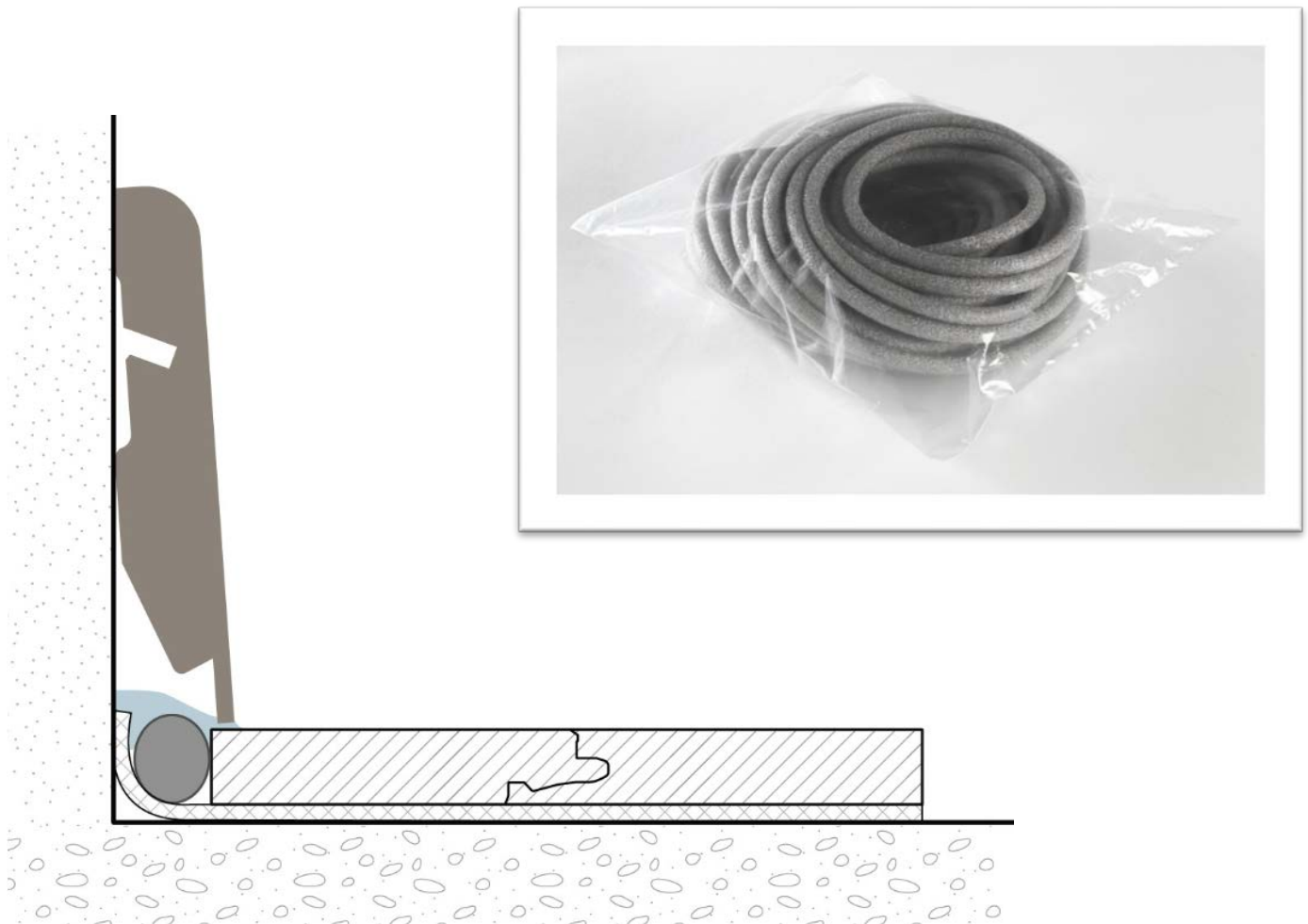

(Impressive) – Wallbase

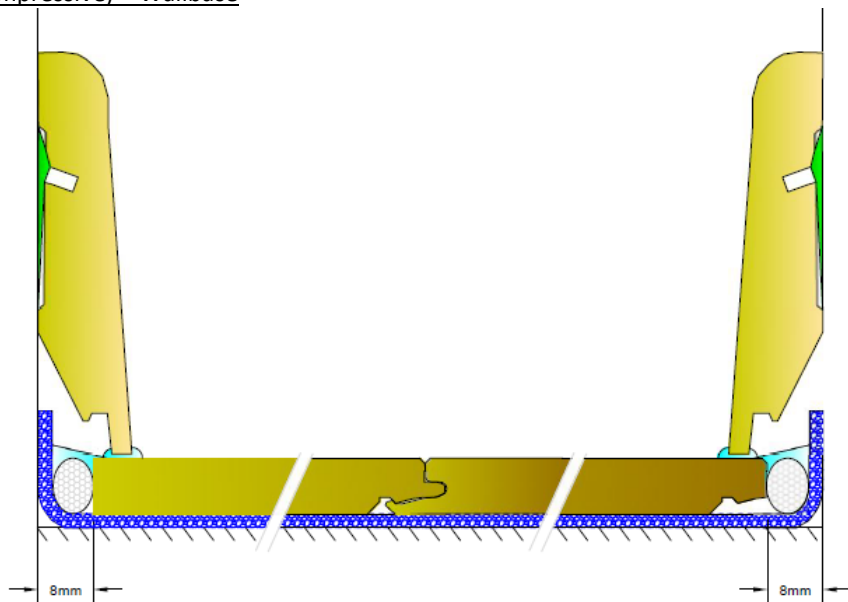

(Impressive) - Doorframe

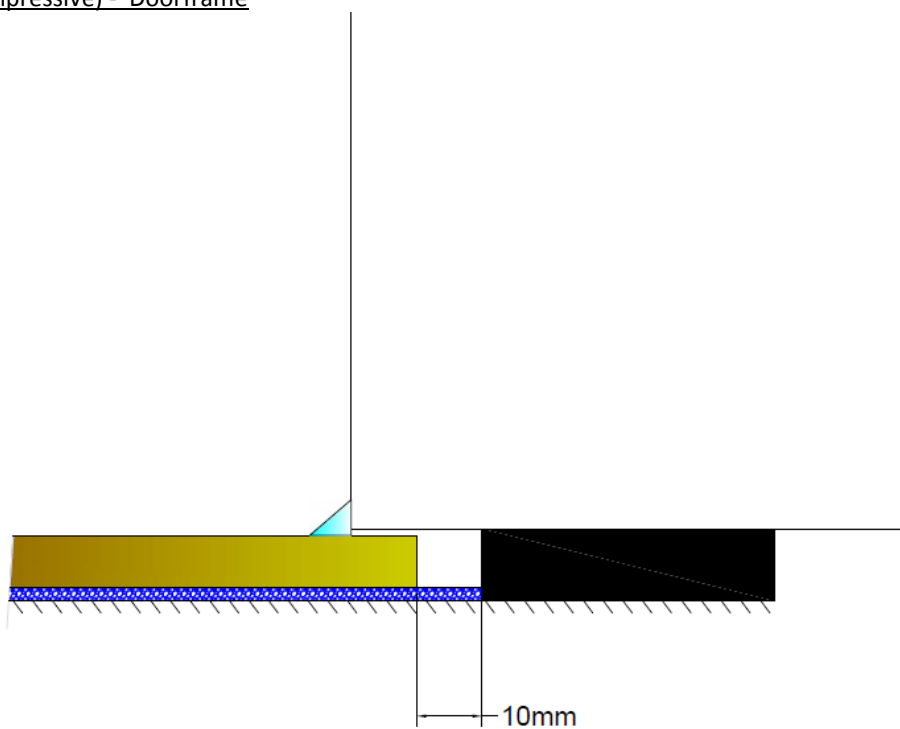

1. T-application

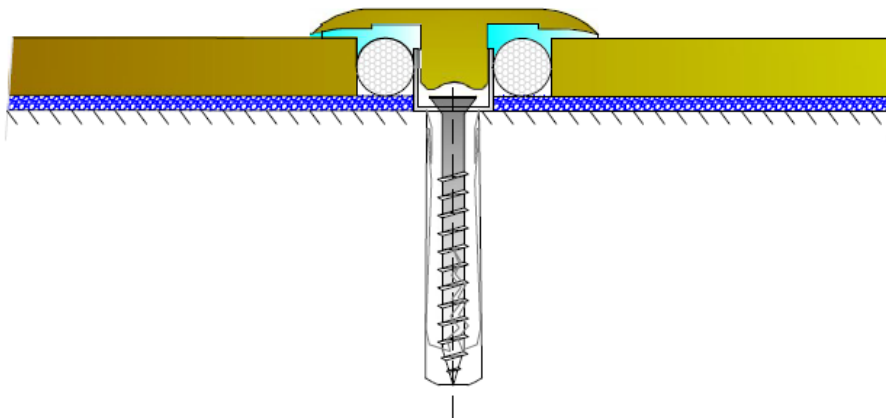

2. End-application

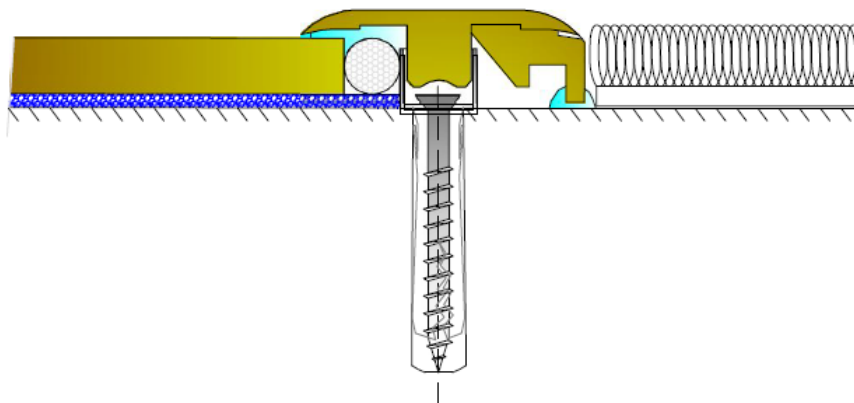

3. Adaptor – application

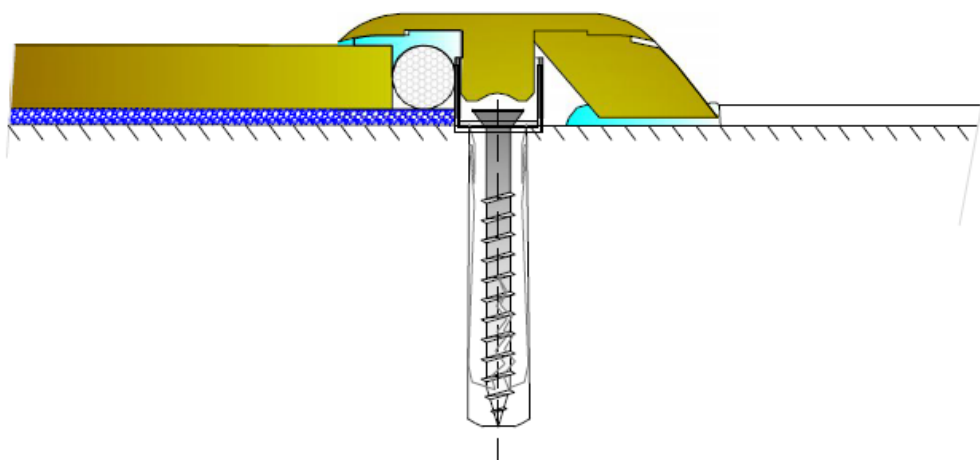

Radiator pipe without pipe cover

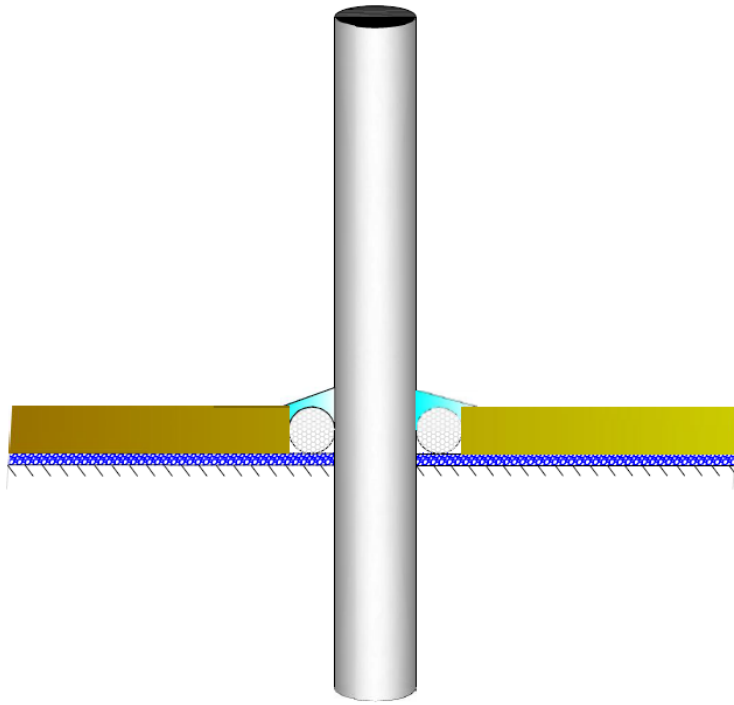

Radiator pipe with pipe cover

